

Schieberhaltevorrichtungen

Slide holding devices

Verrous de tiroirs

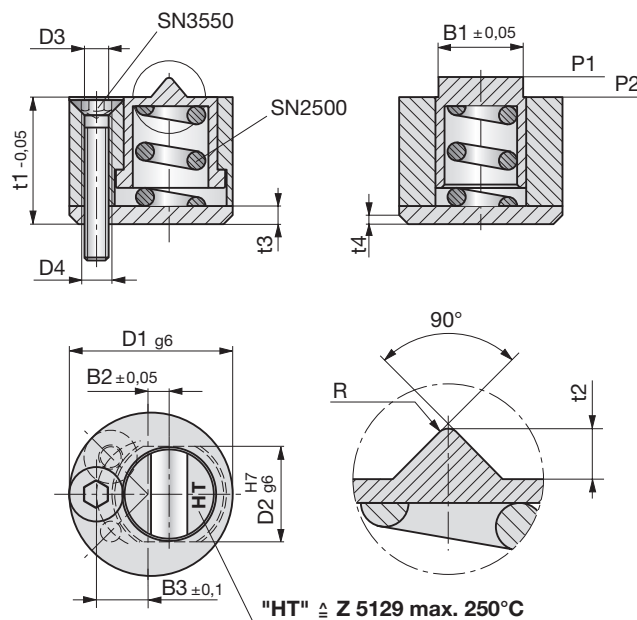

Z5129-
Z5130-

Mat.: 1.2767
~52HRC

Z5129-D1
Z5130-D1



5

Z5129 max. 250 °C

Z5130 max. 100 °C

D1	B1	B2	B3	t1	t2	t3	t4	D2	D3	D4	R	P1	P2	P1 (HT)	P2 (HT)	SN2500-	SN3550-
13	6,6	1,4	4,3	10	1,0	1,6	0,35	7	2,2	M3	0,35	28 N	34 N	21 N	28 N	5-12	M2-16
18	9,6	2,0	6,0	14	1,8	2,0	0,50	10	3,2	M4	0,50	38 N	42 N	26 N	35 N	8-16,5	M3-20
27	14,4	3,0	9,0	21	2,8	3,0	0,50	15	4,3	M5	0,75	38 N	92 N	33 N	82 N	11,6-18,5	M4-25

