

Um die Lebensdauer des Schließkontaktes zu erhöhen, empfehlen wir ein Überfahren des Schaltpunktes um ca. 0,15 - 0,3 mm.

In order to increase the lifetime of the make contact, we recommend travelling approximately 0.15 - 0.3 mm beyond the switching point.

Pour augmenter la longévité du contact de fermeture nous recommandons de dépasser le point de contact de commutation d'environ 0,15 à 0,3 mm.

Schaltzeichen im geschalteten Zustand dargestellt.
Sa = Arbeitsschaltabstand.

Graphical symbols shown in switched position.
Sa = Work-switching gap.

Contacteur symbolisé en position « Marche ».
Sa = L'intervalle de commutation de travail.

Zubehör

Accessories

Accessoires

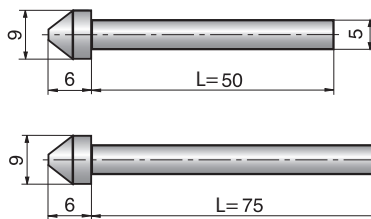
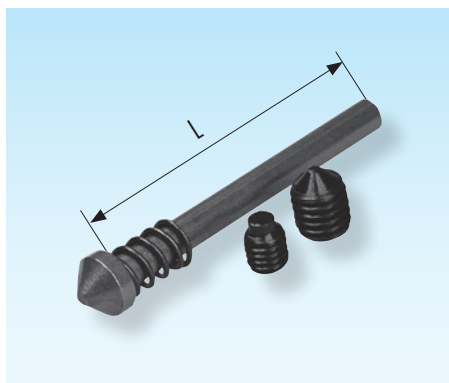

Vor Einsatz entfernen.
Remove before utilisation.
Eloigner avant l'utilisation.

Z7608-

Mat.: St

L

50

75

Z7608-L



Bezeichnung	Designation	Désignation	Stück Qty. Quant.	Abmessungen Dimensions Dimensions	DIN Nr. DIN-No. Réf. matière
Kegelstift	Tapered pin	Tige conique	1	L 50 / L 75	
Feder	Spring	Ressort	1	Dm 7, Lo 15	DIN 2098
Einstellschraube	Adjusting screw	Vis de réglage fin	1	M8 x 10	DIN 914
Stiftschraube	Locking screw	Vis de blocage	1	M6 x 8	DIN 915