

Temperierbrücken

Deflection elements

Éléments de déviation

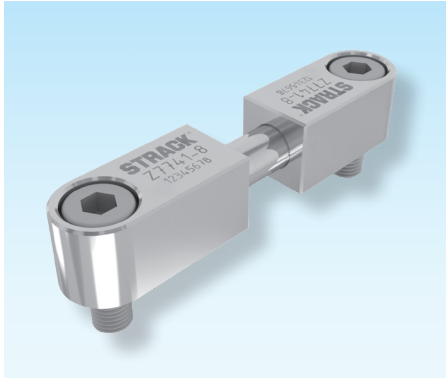

Z7741-

Mat.: 1.4301/FKM (Viton)



Z7741-D-L

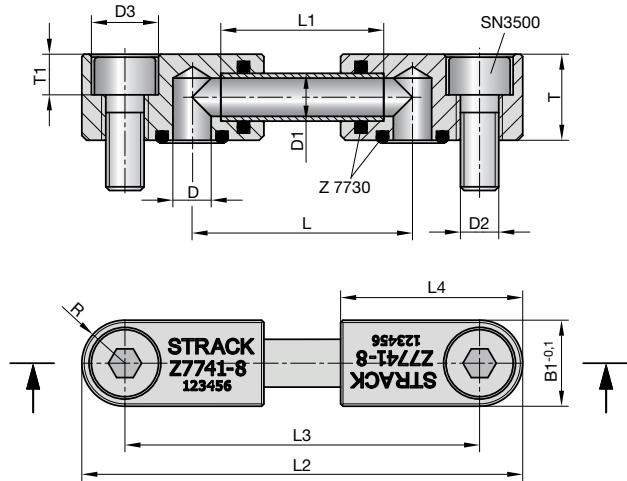
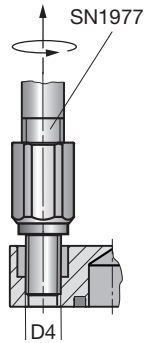

t max. = 180 °C

Zylinderschrauben im Lieferumfang enthalten
Cylinder head screws included in delivery
La livraison contient vis à tête cylindrique

D	L	L1	L2	L3	L4	B1	D1	D2	D3	D4	T	T1	R	SN3500	Z7730
8	125	113	171	153	38	18	10	M8	14	M10	18	8,5	9	M8-20	10-2,5
8	250	238	296	278	38	18	10	M8	14	M10	18	8,5	9	M8-20	10-2,5
8	500	488	546	528	38	18	10	M8	14	M10	18	8,5	9	M8-20	10-2,5

7

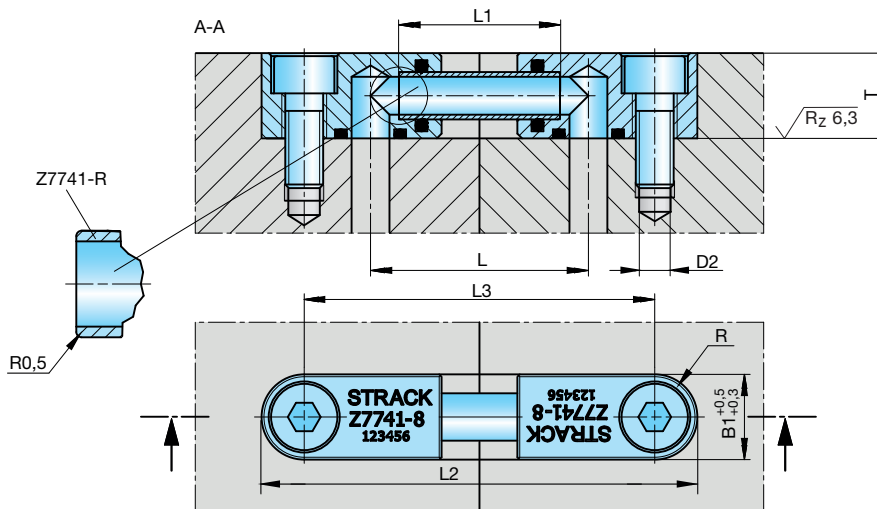
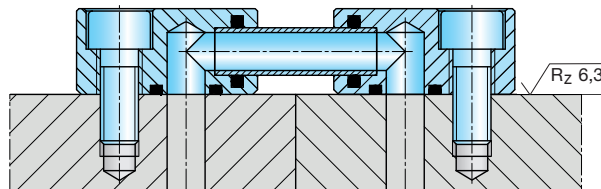

L1 = L-12
L2 = L+46
L3 = L+28

L1 - Lieferlänge - kundenseitig kürzen und Radius anbringen
Standard length of the product supplied - shortening and radius to be done by the customer
Longueur de livraison - abrègement et rayon doivent être effectués par le client